

FOURWHEEL DRIVE DUMPER

CAPACITY:

Max. safe load:	10000 kg
Heaped:	5070L
Struck:	4140L
Water:	2400L

ENGINE:

JCB444T 4 cylinder Turbo with After Cooling	
Displacement:	4.4 L
Max. power:	97KW/130bhp @ 2200 rpm
Max. torque:	525Nm @ 1300 rpm
Emissions:	Euro 3 compliant

TRANSMISSION:

Torque converter c/w 4 speed forward and reverse power shuttle transmission
Permanent 4 wheel drive

DRIVE CHARACTERISTICS:

Forward / Reverse	1st	0-4.9 km/h (0-3.1 mph)
	2nd	0-7.0 km/h (0-4.9 mph)
	3rd	0-16.9 km/h (0-10.6 mph)
	4th	0-32 km/h (0-20 mph)
Steering angle:	+/- 30°	
Turning circle:	12.85m	
Grade-ability:	50%	
Tyres:	500/60 R22.5 (traction Profile)	
Steering:	Priority load sensing hydrostatic centre pivot	
Working brakes:	Multi-plate oil immersed discs mounted on both axles	
Park brake:	Hand operated, locking on dry disc acting on gearbox	

NOISE LEVELS:

LWA	104dB(A)
LPA	85dB(A)

TANK CAPACITIES:

Fuel:	70L
Hydraulic:	70L

SKIP:

Manufactured from higher tensile steels
Hydraulically operated skip tipping to over 90°
Heavy duty fully welded skip with 8mm thick steel base, reinforced upper side walls for greater strength
Operated by a multi axis joystick for increased performance

ELECTRICAL:

Heavy duty 60045 Battery: 12V, 185Ah 1000CCA
Wiring harness in protective sleeving
Reversing alarm

HYDRAULICS:

Hydraulic test points fitted as standard
Easy access return oil filter on top of tank
Easy access pressure filter

SEATING & CONTROLS:

Adjustable suspension seat accessible from both sides
Clear access across dumper via galvanised steps
Extra wide brake pedal
Super bright warning lights on fully featured display instrument
Steel constructed centre console for extra leg protection
Operator level gear selection lever with integrated clutch button
Column mounted directional control lever
Heater vent at foot level
Anti-slip floor
Horn operable from joystick

SERVICE ACCESS:

Easy access for service maintenance
Lockable hinged engine cover
Battery mounted in lockable step compartment
Lockable tool box compartment on step
Separate lockable fuel & hydraulic filler flaps

We reserve the right to change the above specifications without prior notice

ST10

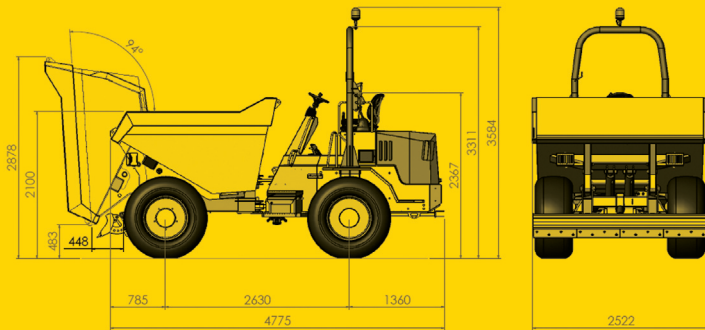

FEATURES

- Unrivalled operator accessibility and comfort
- Excellent rough terrain performance from permanent 4-Wheel drive
- Heavy duty construction; skip manufactured from 8mm steel plate and reinforced around top
- Column operated forward and reverse directions with acceleration by foot pedal
- Simple and safe operation; drive direction on the steering column
- Heavy duty centre console for leg protection
- Simple instrument panel including fuel gauge, hourmeter, warning lights for parking brake, oil temperature, oil pressure, engine temperature
- Folding ROPS as standard
- Easy access to engine compartment for service and maintenance
- Recovery brackets as standard
- 130 HP engine /97 Kw
- Excellent power to weight ratio
- Theft deterrent Cesar Data Tag System as standard
- Ample ground clearance
- Superior turning circle
- Reversing alarm standard
- Handbrake safety device - will not move until released
- Lockable toolbox and battery compartment, both fully galvanised
- Separate fuel and hydraulic filler compartment
- Adjustable steering column
- Adjustable suspension seat
- Skip tips over 90°
- Electronic drive by wire throttle system
- Skip manufactured from higher tensile steels
- Flashing beacon

OPTIONAL EQUIPMENT

- Road Light Kit
- Spare Wheel
- Biodegradable Hydraulic Oil
- FOPS Roof
- Skip manufactured from Hardox
- Cab
- Shovel, spade and brush holders



NC Engineering (Hamiltonsbawn) Ltd
2 Killyrudden Road, Hamiltonsbawn
Richhill, Co Armagh
Northern Ireland BT61 9SF

Tel: +44 (0) 28 3887 1970
Fax: +44 (0) 28 3887 0362

Email: sales@nc-engineering.com
Web: www.nc-engineering.com