

FOURWHEEL DRIVE DUMPER

CAPACITY:

Max. safe load:	1500 kg
Heaped:	805L
Struck:	600L
Water:	420L

ENGINE:

Kubota D1105 3 Cylinder, Water Cooled, Naturally Aspirated	
Displacement:	1.1 L
Max. power:	17.5kW/23.4bhp @ 2800 rpm
Max. torque:	72Nm @ 2000 rpm
Emissions to:	97/68/EG

TRANSMISSION:

Hydrostatic automotive "Twin Lock" permanent 4 wheel drive
Acceleration by foot pedal & braking from hydrostatic retardation

DRIVE CHARACTERISTICS:

Forward / Reverse	0-11 km/h (0-7 mph)
Steering angle:	+/- 36°
Turning Circle:	6.4m
Grade-ability:	50%
Tyres:	10.0 / 75 / 15.3 (traction Profile)
Steering:	Priority load sensing hydrostatic centre pivot
Working brakes:	Hydrostatic retardation
Park brake:	Automatic in rear wheel motors

NOISE LEVELS:

LWA	99dB(A)
LPA	82dB(A)

TANK CAPACITIES:

Fuel:	28L
Hydraulic:	24L

SKIP:

Hydraulically operated skip tipping to 90°
Heavy duty fully welded skip with 5mm thick steel, reinforced around top for greater strength
Operated by a twin levers for increased performance

ELECTRICAL:

Heavy duty H075 Battery: 12V, 550CCA, 59Ah
Wiring harness in protective sleeving
Reversing alarm

HYDRAULICS:

Automotive control hydrostatic pump
8cc Gear pump
Hydraulic test points fitted as standard
Easy access return oil filter on top of tank

SEATING & CONTROLS:

Adjustable suspension seat accessible from both sides
Clear access across dumper via galvanised steps
Super bright warning lights on fully featured display instrument
Steel constructed centre console for extra leg protection
Column mounted directional control lever
Anti-slip floor

SERVICE ACCESS:

Easy access for service maintenance
Lockable hinged engine cover
Battery mounted inside the engine bay

HT1.5

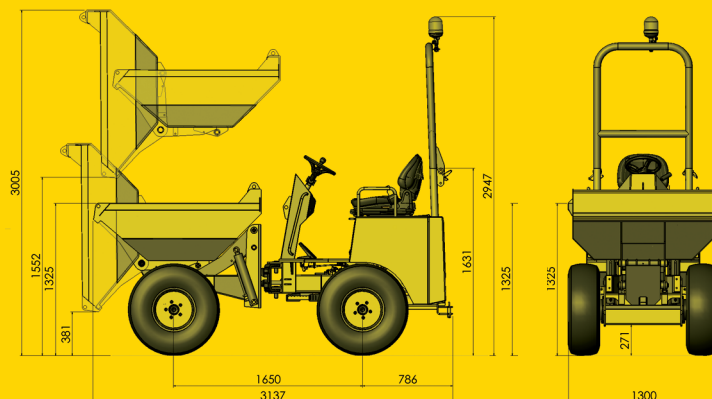

FEATURES

- Unrivalled operator access & comfort
- Excellent rough terrain performance from permanent 4-wheel drive
- Heavy duty construction
- Column operated forward and reverse directions with acceleration by foot pedal
- Simple and safe operation; drive direction on the steering column
- Simple instrument panel including fuel gauge, hour meter, warning lights for parking brake, oil temperature, oil pressure, engine temperature
- Folding ROPS as standard
- Flashing beacon as standard
- Easy access to engine compartment for service & maintenance
- Recovery hitch as standard
- 23.4 HP engine (17.5kW)
- Excellent power to weight ratio
- Ample ground clearance
- Excellent turning circle
- Reversing alarm as standard
- Separate fuel and hydraulic oil filler compartments
- Skip tips to 90°
- Adjustable suspension seat

OPTIONAL EQUIPMENT

Road lights kit
Spare wheel
Trailer socket
Skip manufactured from ST52 or Hardox
Cab



NC Engineering (Hamiltonsbawn) Ltd
2 Killyrudden Road, Hamiltonsbawn
Richhill, Co Armagh
Northern Ireland BT61 9SF

Tel: +44 (0) 28 3887 1970
Fax: +44 (0) 28 3887 0362

Email: sales@nc-engineering.com
Web: www.nc-engineering.com